

SASSOMECCANICA spa
Via del Lavoro, 2
63076 Montepreandone / AP / Italy
T. +39.0735.650988
F.+39.0735.657741
P.IVA 00342060449

www.sasso.it

info@sassomeccanica.it



MAKE IT EASY



M1_V6.2

HANDBOOK COMPOSITION

The operative handbook of the machine “M1-03” is based on the following points:

GENERAL INFORMATIONS: instructions about handbook and machine maintenance. Builder and machine identification data.

MACHINE DESCRIPTION: it contains a machine description based on the purposes of its design.

MACHINE UPLIFT: it underlines the machine hooking points for its uplift.

CONNECTIONS: it shows the points for a correct power, compressed air and water connection.

LEVELLING: machine process for the levelling.

DANGER ZONE DEFINITION: it explains the zones considered dangerous during the standard work of the machine. These zones can be reached only when the machine is not working.

WARNINGS: it contains all the useful tips to avoid situations which can be dangerous for the worker.

NOISE: it contains all the information about noises produced by the machine.

INSTRUCTIONS FOR USE: it contains all the instructions for a correct use of the machine.

LUBRICATION: it shows all the points which need a periodical lubrication.

MAINTENANCE: it describes ordinary repairs operations charged to the user.

OTHER INFORMATIONS: it contains all the information and solutions concerning the most common breaks down.

LAYOUTS: it contains electrical, pneumatic and plumbing layout.

GENERAL INFORMATIONS

Important: keep this handbook for present and future consultations. In case of machine sale or transfer to another user, make sure that the handbook is with the machine; in this way the new owner will be able to inform himself about machine functioning.

In case of stopping activity, the machine must remain in the laboratory without being uninstalled.

Please read carefully these information before machine installation, connection and use.



Building company

SASSOMECCANICA Spa
Via del Lavoro 2
63076 Montepiccolo (Ascoli Piceno)
ITALY

Telephone number. 0039 0735 650988

SERVICE 0039 0735 651623 service@sassomeccanica.it

MACHINE IDENTIFICATION:

		ITALIA - 63039 PORTO D'ASCOLI (AP) Via Val Tiberina, 73 Tel. +39 - 0735.650988 Fax +39 - 0735.657741 www.sassomeccanica.it e-mail: info@sassomeccanica.it			
MACCHINA MODELLO MACHINE TYPE	<input type="text"/>	TENSIONE NOMINALE RATED VOLTAGE	<input type="text"/>		
MATRICOLA N° SERIAL NUMBER	<input type="text"/>	FREQUENZA FREQUENCY	<input type="text"/>		
ANNO DI COSTRUZIONE CONSTRUCTION YEAR	<input type="text"/>	NUMERO DI FASI NUMBER OF PHASES	<input type="text"/>		
PESO (KG) WEIGHT (KG)	<input type="text"/>	POTENZA NOM. (kw) NOM. POWER SUPPLY (kw)	<input type="text"/>		

The model machine with the identification number and the main characteristics are on the label fixed on a visible side of the machine.

Regulation applied:

- EN 60264.
- Directive 2014/35/UE- Low Tension Directive.
- Directive 2014/30/UE- Electromagnetic Compatibility Directive.

MACHINE DESCRIPTION

The bridge saw model M1 is built with strong iron girders, advisably reinforced. M1 project privileges the bench stability, compensating the cutting depth through disc climb and fall movements, and brings out vibrations damping thanks to its building techniques. One of its particular characteristic is that to be totally filled with expanded materials which give sound-proof and vibrating-proof function.

The main machine controls are on a fixed panel placed in better position to control machine movements. The handle movement controls, to place the disc on the section to cut, are placed on a mobile panel used by the owner for every machine movement, bench rotation block included.

Advance and return movement of the wagon disc carrier is assigned to the engine system and inverter brushless, and it's controlled by encoder.

The movement linkage is constituted by elements which don't allow mechanical effects. The same system is adopted for the bridge movement, so that measures of movement with strict tolerances are guaranteed. This system doesn't need regulations over the time.

The bridge saw M1 is realized in the maximum disc version Ø 625; above this it is possible to install the following accessorizes:

- Cutting granite marble programme with interpolation of the axes for straight, oblique and curved cuttings.
- Reclining head up to 90 degrees.
- Laser cutting indicator.
- Folding bench.
- Rotating bench.

The simplicity of manoeuvre and programming make M1 an easy and safe machine, the easiness of action and the so poor maintenance make the handling really cheap.

In conformity to the current measures, during the planning of the M1 machine, our attention really focused on ergonomics and safety work and therefore it meets all the requirements needed for the apposition of the **CE** mark.

Use conditions: machine's working conditions are guaranteed in environments where the temperature ranges from 5° to 40° degrees, and the humidity from 35% to 85%.

MACHINE UPLIFT

UPLIFT AND HOOKING POINTS

When it is necessary to remove the machine, it's extremely important to use only the hold points, as it will be explained later on, both to avoid damages to the machine and dangerous situations for the workers. In addition it is necessary to fix the bridge in the correct position to allow to the machine to move and to keep machine balance.

In the following images you will find the general levelling plan and the specific hooking points of the machine.

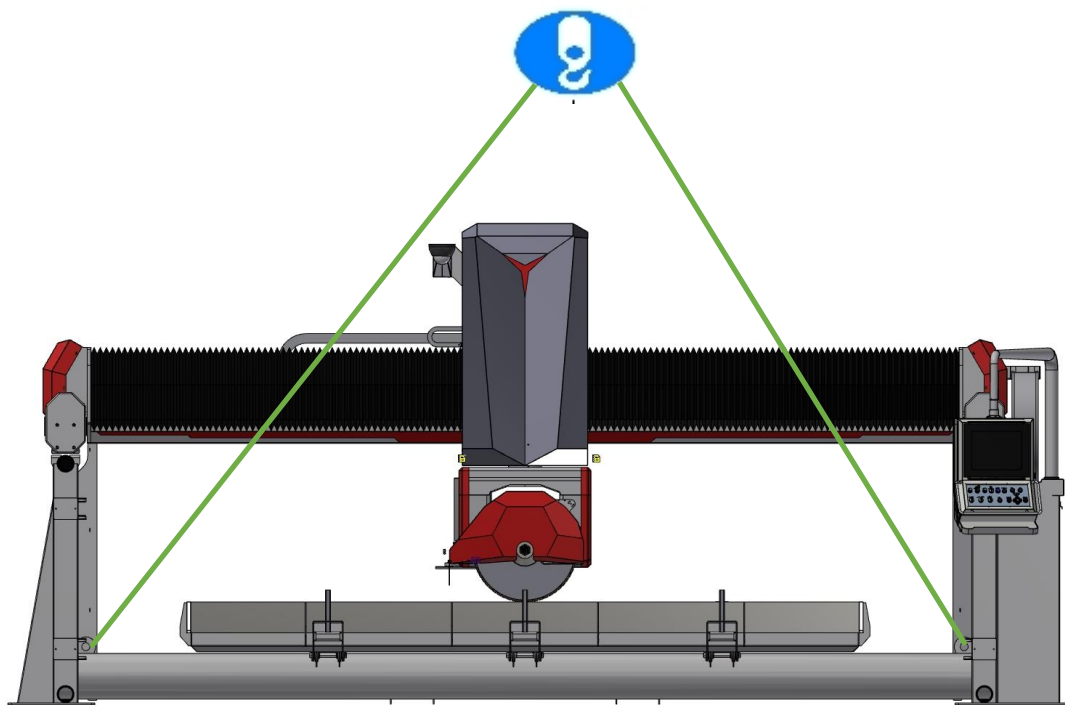



Before moving and levelling the machine or the various components be sure that the levelling organs used (overhead travelling crane, crane, cables etc.) are suitable to bear the specified loads (see the section concerning the technical characteristics).

LAYOUTS

LAYOUTS

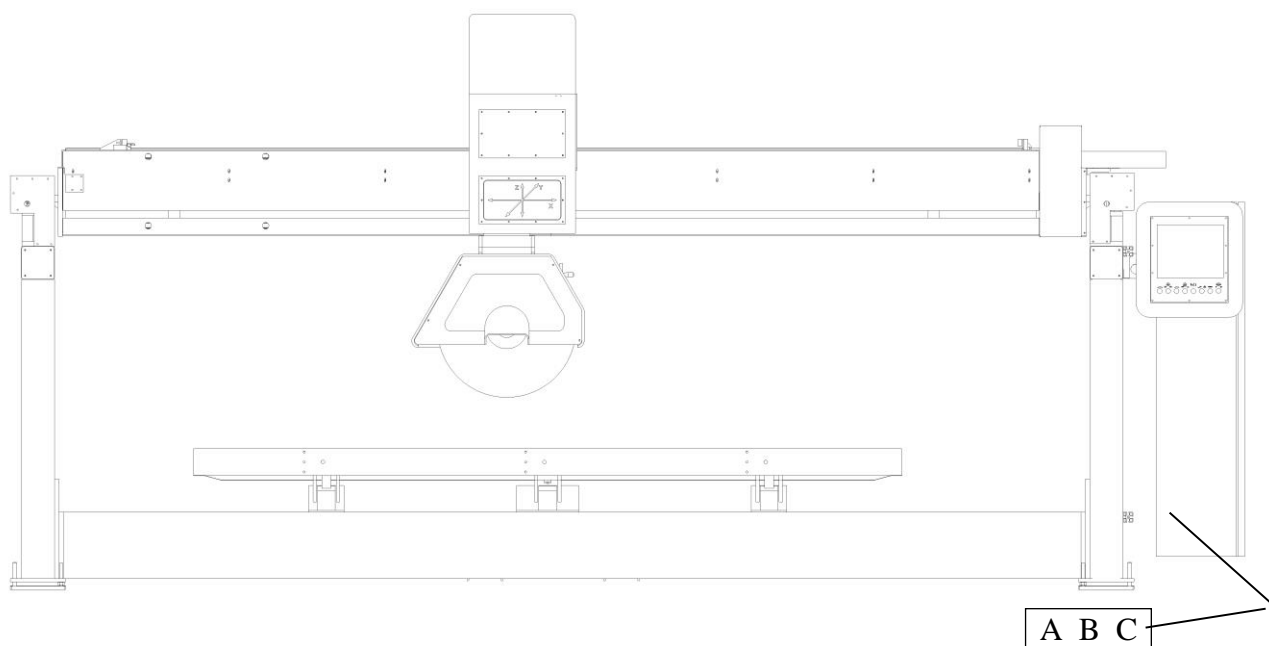

In the picture you can find the layouts for the needed points of supply.

A) ELECTRICAL LAYOUT

Place next to the machine a differential polar switch of 80 Ampere and with a sensibility of 0.3, for machines with inverter on board.

Connect the electric power taken from the switch using a safety standards cable, with a minimum section of 3 x 25 square millimetre. Insert the cable in the electric panel through the provided passage and connect it to the provided terminals. Connect the ground cable to the terminal cable of the electric panel.

To test the polarity of the supply you have to operate the disc march control immediately followed by the stop control, then verify the sense of rotation which must be in a clockwise direction. If it turned in a anticlockwise, change the central supply line with one of the two lateral lines and repeat the check. In the case of a machine with disc inverter optional, verify the supply phase using the control of climb and decline of the disc.

B) WATER LAYOUT

Make the water supply layout in the point indicated in the picture using a rigid main of the section of 1/2" Gas (40 lt/min minimum). It is advisable to interpose a closing tap before the layout to the machine.

C) COMPRESSED AIR LAYOUT

Make the compressed air supply layout in the point indicated using a standard pipe 1/4" Gas. It is advisable to interpose a closing tap before the layout to the machine.

It is extremely important to put into the machine clean and dehumidified air to not damage the internal pneumatic components.

MACHINE LEVELLING

Before making any movements of the axes it's necessary to do the machine levelling, using a transparent pipe for water which must be really flexible: 10 mm diameter and 6 meters length.

The regulation screws can be completely unscrewed on the four feet of the machine.



The pipe is filled with water up to 10 cm from the two ends and through the levelling labels on the four columns. The labels are placed in order to find the highest label.

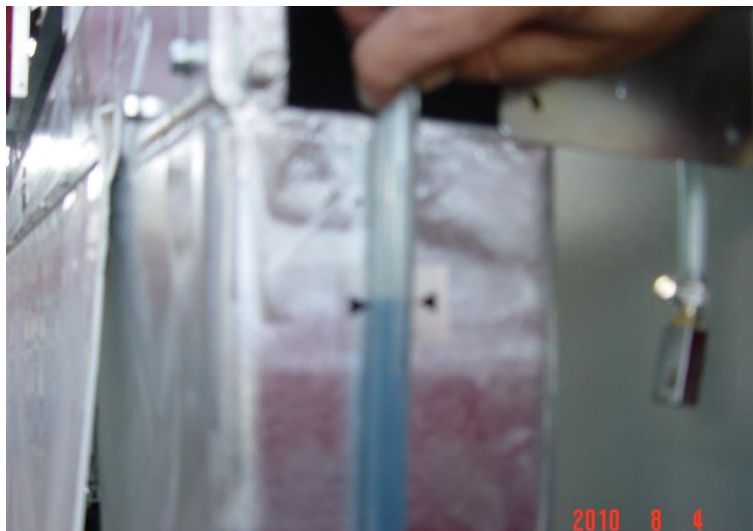

Fix an extremity of the pipe upon the highest column using some gammed paper, the regulate the crews on the bases support, up to the lines of the 4 labels are on the same level.

In this way the machine is completely levelled of and it's ready for the resetting of the axes.

During this regulation it is important to completely stabilize the level of the water in the pipe evry time you make a control.

DANGER ZONE DEFINITION

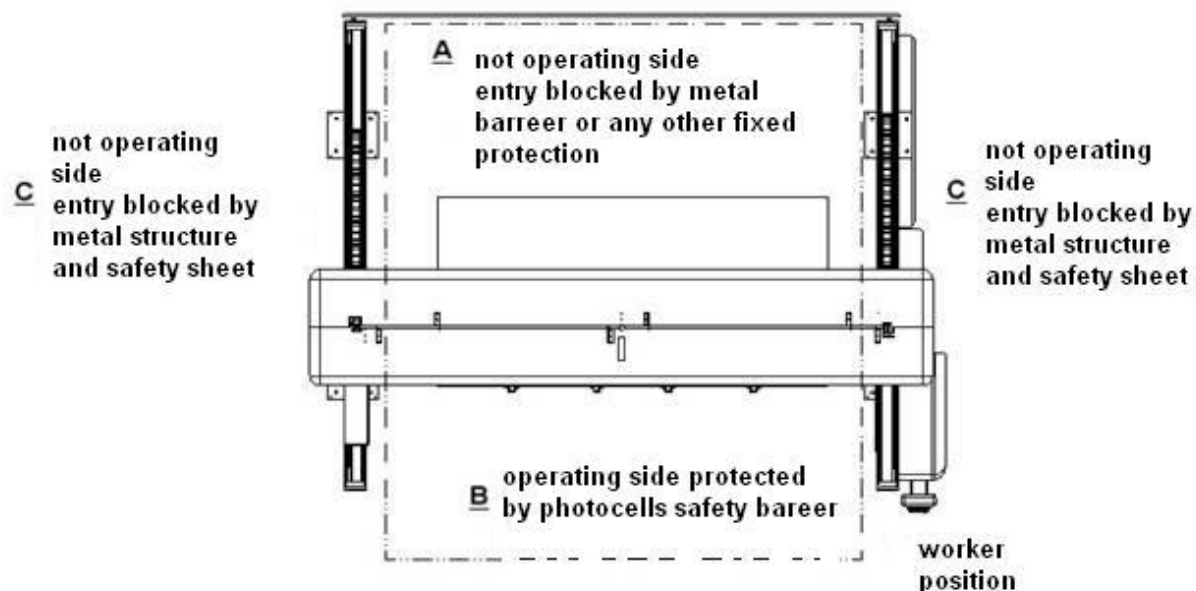

Both protections must be verified in their presence and functionality, before using the machine. This can be done only by the specialised staff who works with it.

“M1” panel control can be transported to position the machine and prepare it in a more easy way to the programming.

It's strictly forbidden to access to machine's danger zone through different sides by that specified with the letter “B” (frontal side protected by safety barrier); access is allowed for maintenance interventions and material load/unload only when the machine is not working.

Moreover, Because of in the moving control panel there's not a disc start control and a cycle start control, the worker must get out of the danger zone to start the disc and the automatic programme.

Even after the machine stop command, the security system remains in action for all the time necessary to the complete stop of the disc which, in normal working conditions happens through inertia.

It's strictly forbidden to remove all the protections of the machine that is to say, lateral, back (considered fixed) and frontal (safety cable barrier)

GENERAL INSTRUCTIONS

INSTRUCTIONS

It's strictly forbidden to access to danger zone, that is to say machine central zone, without stopping the machine in advance.

It's strictly forbidden to remove fixed machine protections, without stopping the machine in advance and putting it in the emergency phase.

It's strictly forbidden to open mobile machine protections, without stopping the machine in advance and putting it in the emergency phase.

It's strictly forbidden to try to substitute tools when the machine is working.

It's strictly forbidden to open the electric panel without disconnect the machine

It's strictly forbidden to lubricate, maintenance, or regulations of mechanic organs without disconnect in advance the machine.

It's strictly forbidden try to approach the disco if this is not completely stopped and if the machine is still working.

It's strictly forbidden to remove safety devices from the machine.

It's strictly forbidden to modify the machine without the permission of the producer.

POSTER DESIGNING MACHINE BOARD

Here you can find all the signals concerning danger, rule and prohibition which draw user attention about the risk and the behaviour to adopt when the machine is working.

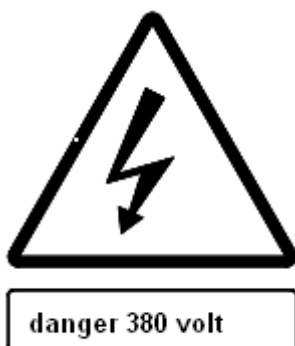

The following danger signal is normally placed on the box containing the electric panel. A door block mechanism doesn't allow to open the door without have disconnected the machine.



This signal shows that you do not to engage in operations of any kind in specific areas of the machine before removing from power so any intervention, even accidentally, in the command can not create hazardous conditions.

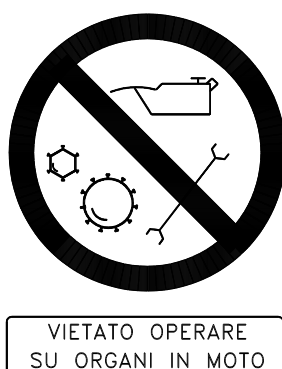

it's strictly forbidden to make any kind of operation (as recording, lubricating, repairing etc...) on organs on the go, even if you don't need to access to the zone identified as dangerous to make this kind of operations.



This signal indicates the grip points for the total or partial uplift of the machine. It's strictly forbidden to move the machine during the uplift using grips points different from that indicated.

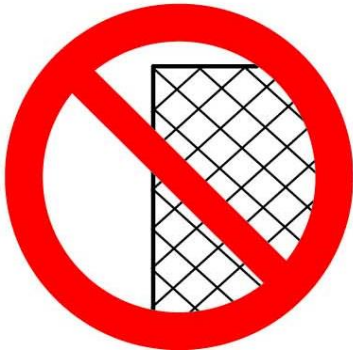

This signal indicates the absolute prohibition to cross the fixed barriers and with photocells, which are the borderline of the danger zone.



This signal indicates that workers need to wear casing to protect your ears during all the time they work near the machines.

NOISE

INFORMATION CONCERNING THE NOISY EMISSIONS DURING THE NORMAL CONDITIONS OF USE AND THE RISKS DERIVING FROM THE USE OF THE BRIDGE SAW

1) GENERAL TECHNICAL INFORMATIONS:

The bridge saw "M1" is composed of a base in metallic carpentry relied on the floor; it supports the tracks for the running of the bridge.

It is possible to assemble above the head two different kind of tools: cutting disc of various diameters and diamond saw to burst or to bore.

The source of noise is basically constituted by the cutting disc of the different diameters which work removing material at a really high cutting speed. While saws work with a slower cutting speed.

For further technical details see the "USE AND MAINTENANCE HANDBOOK".

2) MACHINE'S RESONANT POWER LEVEL

The machine was projected and realised to reduce at the source the level of resonant emission.

Surveys were carried out according to the measure method of the law EN ISO 4871-1995, EN ISO 11200-1995, EN ISO 11202-1995, Decree with the force of the law 81/2008 Law 447/95.

The machine generates noise in the following measure:

WORKING MACHINE WITHOUT PIECES IN PROCESSING

From 80,0 DB(A) a 81,5 DB(A)

WORKING MACHINE WITH PIECES IN PROCESSING

The values expressed refer to the machine at work and were registered in different points, at a medium distance of 1 meter by the noise source.

For the measurements carried out the maximum value of the acoustic instantaneous pondered pressure C results lower than 130 DBA

MACHINE BACK SIDE

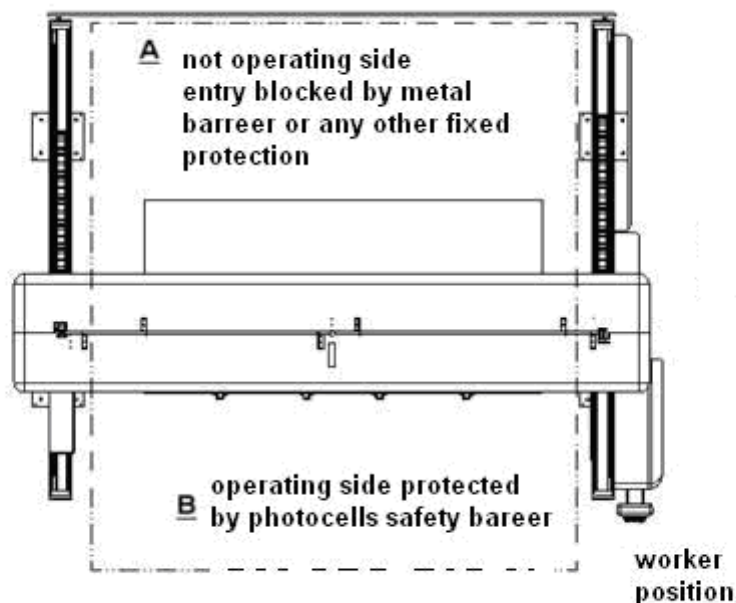

MACHINE FRONT SIDE

3) SONOROUS LEVEL EQUIVALENT IN CORRESPONDANCE OF THE WORKING POSITION

Working machine with piece in processing:

Decibel zone working front side = db(A) 85,4

Decibel zone working back side = db(A) 83,3

4) NOISE AMOUNT ABSORBED ON THE BASE OF THE TIME OF EXPOSITION

EQUIVALENT SONOROUS LEVEL CALCULATION (Leq)

Exposition in minutes	Front side		Back side	
	db(A)	Leq	db(A)	Leq
60,0	85,5	76,5	83,3	74,3
120,0	85,5	79,5	83,3	77,3
180,0	85,5	81,2	83,3	79,0
240,0	85,5	82,5	83,3	80,3
300,0	85,5	83,5	83,3	81,3
360,0	85,5	84,3	83,3	82,1
420,0	85,5	84,9	83,3	82,7
480,0	85,5	85,5	83,3	83,3

5) VALUE OF THE AIR NOISE PRODUCED BY THE MACHINE

Acoustic continuous equivalent pondered pressure level (A) registered in the working place by the operator is from 83,3 to 85,4

The following noise values are levels of emission and they don't represent safe operative levels.

Even if there's a relation between exposition and emission levels, this can't be employed in a reliable way to establish if some precautions are necessary or not.

The factors which determine the exposition level to which the workers undergo, include the time of the exposition, the characteristics of the work place and others noise sources (for example: number of machines, adjoining operations etc...)

In every case, the mentioned information, will allow the user to evaluate in the best way the risks and the dangers he undergoes

6) TECHNOLOGIES EMPLOYED FOR THE REDUCTION OF THE NOISE EMITTED BY THE MACHINE

The noise produced by the cutting disc used to create the channels, so as those to mould the materials, can be pull down by the carter disc built in iron for the resistance, but covered with a not metallic material for the soundproof function.

During the right use of the machine, vibrations don't represent a dangerous situation.

USE OF THE MACHINE

PANEL CONTROL

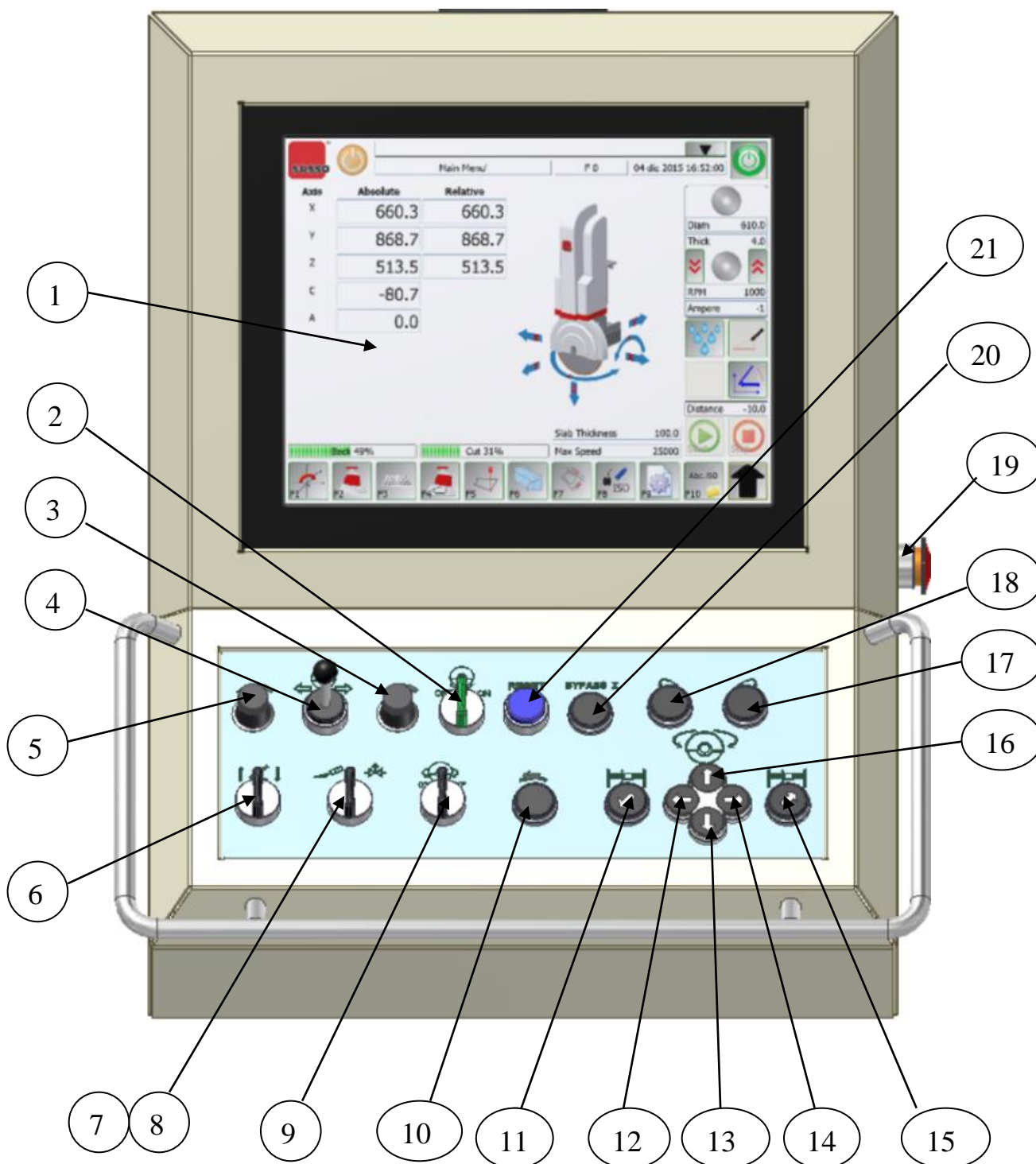

- 1) User terminal
- 2) Selector on/off disc engine
- 3) Potentiometer disc cutting
- 4) Master controller cutting/return
- 5) Potentiometer disc return
- 6) Selector UP and DOWN table (optional)

- 7) Selector on/off cutting laser line
- 8) Selector open/close water
- 9) Selector (0°- 90°) C axes
- 10) Fast movement in jog
- 11) Jog for back bridge movement (Y negative)
- 12) Jog for left head movement (X negative)
- 13) Jog for lower head movement (Z negative)
- 14) Jog for right head movement (X positive)
- 15) Jog for forward head movement (Y positive)
- 16) Jog for lift head movement (Z positive)
- 17) Jog for clockwise head movement (C negative)
- 18) Jog for counter-clockwise head movement (C positive)
- 19) Emergency button
- 20) Reset Z axis
- 21) reset auxiliary tension

CONTROLS DESCRIPTION

1 = KEYBOARD AND DISPLAY PC CONTROL

Touch screen keyboard and display allow to send to the machine control all the necessary data to work, and to read the indications given by the operator.

2 = SELECTOR ON/OFF DISC ENGINE

This selector allows the start-up and stopping disc rotation. The disc start-up is possible only from this fixed panel controls, because it's outside the danger zone. The disc start-up activates the safety barrier working which remains operable up to 20 seconds after the stopping disc control, to keep active the security during the stopping disc inertia.

3 = POTENTIOMETER DISC CUTTING

It allows to regulate in a direct way the cutting speed along X, Y and in the oblique cuts.

4 = MASTER CONTROLLER CUTTING/RETURN

With this temporary positions master controller, it is possible to cut and go back at speed regulated by the potentiometers.

5 = POTENTIOMETER DISC RETURN

It allows to set directly the speed during the return running or back cutting in case of granite.

6 = SELECTOR UP AND DOWN TABLE (optional)

With this selector we can control the up and down movement of the loading slabs table.

The table maximum capacity is 1000 kg.

7 = SELECTOR ON/OFF CUTTING LASER LINE (OPTIONAL)

Whit this selector it switch on and off the cutting line indicator. It is automatically switched off every time the machine start for an automatic programme.

8 = SELECTOR OPEN/CLOSE THE WATER

Whit this selector it opens and closes the water electric valve. In automatic way, it open water every time the tool is running, and close water every time stopped tool rotation.

9 = 0° - 90° ROTATING DISC SELECTOR

Using this select it is possible to turn directly the disc on the two indicated positions. The movement is possible only when the disc is in safety Z position.

10 = MANUAL MOVES FAST BUTTON

Keeping pushed this button, all the movements ordered by the other buttons of this panel, become faster. The state of being contemporary of the two controls for the fast movements, allows the reduction of the residual risk in the lining up operations, when it's necessary to locate the machine with axis manual movement.

11 = JOG FOR Y AXIS BACK MOVEMENT

This button controls the displacement of the bridge in the back direction at slow speed. The limit of the movement is determined by the stop-running software introduced in the machine program data. If used at the same time of the button of fast movements the displacement becomes faster.

12 = JOG FOR X AXIS BACK MOVEMENT

With this button it controls the displacement of the disc in the left direction with slow speed. The limit of the movement is determined by the stop-running software introduced in the machine programme data. If used at the same time of the button of fast movements the displacement becomes faster.

13 = JOG FOR Z AXIS DOWN MOVEMENT

This button controls the disc descent with slow speed. The movement limit is determined by the calibration of the disc actually placed on the machine. If used at the same time of the button of fast movements the displacement becomes faster.

14 = JOG FOR X AXIS FORWARD MOVEMENT

This button controls the displacement of the disc in the right direction at slow speed. The movement field is determined by the two stop-running software introduced in the machine programme data. If used at the same time of the button of fast movements the displacement becomes faster.

15 = JOG FOR Y AXIS FORWARD MOVEMENT

This button controls the displacement of the bridge in the front direction at slow speed. The movement limit is determined by the stop-running software introduced in the machine program data. If used at the same time with the button of fast movements, the displacement becomes faster.

16 = JOG FOR Z AXIS UPPER MOVEMENT

This button controls the disc uplift with slow speed. The movement limit is determined by the stop-running software introduced in the machine programme data. If used at the same time of the button of fast movements the displacement becomes faster.

17 = JOG FOR C AXIS CLOCKWISE ROTATION

Using this button it manually rotates the head in a clockwise sense. If use at the same time of the button of fast movements the movement becomes fast.

18 = JOG FOR C AXIS COUNTER-CLOCKWISE ROTATION

Using this button it manually rotates the head in a counter-clockwise sense. If use at the same time of the button of fast movements the movement becomes fast.

19 = ELECTRIC EMERGENCY

With activation of this button, the machine controls immediately stop all the mechanisms in action.

At the reset of this button, any engine, or other electric parts, move by itself.

20 = AXES Z RESET

With this button is possible to reset the electric emergency, if the cause is on vertical axes, for accidental uplift and micro security intervention. The unlock procedure is: keep pressed the axis Z reset button, while reset and move up Z axis, until the reset is done.

21 = RESET BUTTON

With this button we activate the auxiliary power for the normal working of the machine. Its necessary every time we switch on general power and the blue light on reset button is on.

Before doing any operation on the electric panel, it is necessary to release the door-block and verify the switching off of the voltage alert light.

LUBRICATION

LUBRICATION BEARINGS DISC ENGINE

Note, not all the disc engines need bearings lubrication, for this reason this instruction will be followed only if necessary.



The picture shows the lubrication of the bearings disc engine through the lubricator using fat IP ATHESIA GREASE 2 or equivalent.
In this mechanism it's not possible to see the leakage of fat from the bearing, so the amount is of two complete pumps.

ATTENTION: it's strictly forbidden to make the lubrication before having set the machine in the emergency state.

COUNTER LUBRICATION

All the lubrication points of the counter (fifth wheel, supports, pivots) are collected and placed in the front part of the counter indicated below.



It's important to lubricate with monthly frequency, using fat IP ATHESIA GREASE 2 or equivalent.

During the lubrication of the pivots it is possible to pump the fat up to the lateral leakage, while during the lubrication of the cylinder articulations it must measure out with the two complete pumps.

ATTENTION: it's strictly forbidden to make the lubrication before having set the machine in the emergency state.

- All the linear guideways have a self lubrication system (see image below)

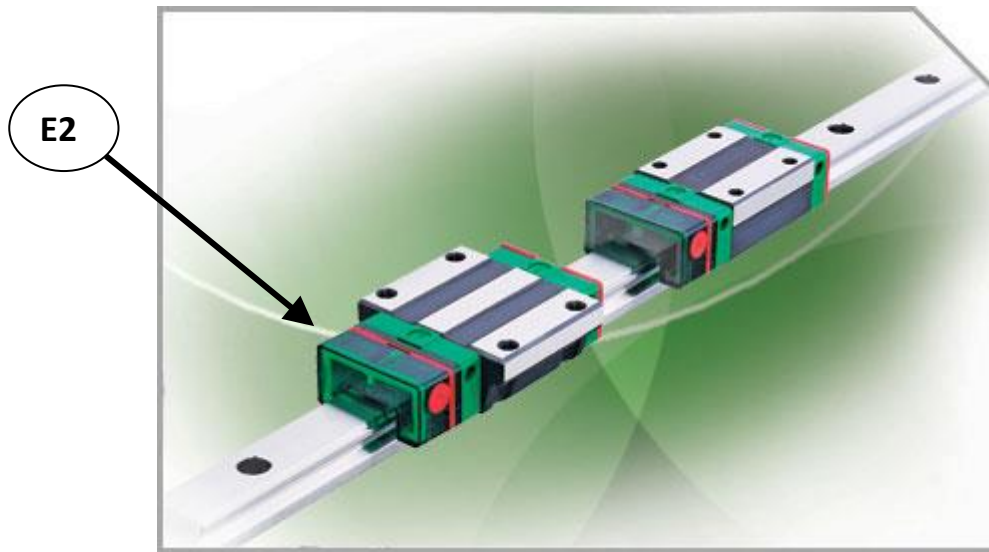

This system is an oil tank (E2) that lubricate the guideway for almost 7000 km and is possible to re-fill it when the tank is empty.

- The two helical racks and the screw of the Z axis are lubricated with a grease tank timed (see images below)

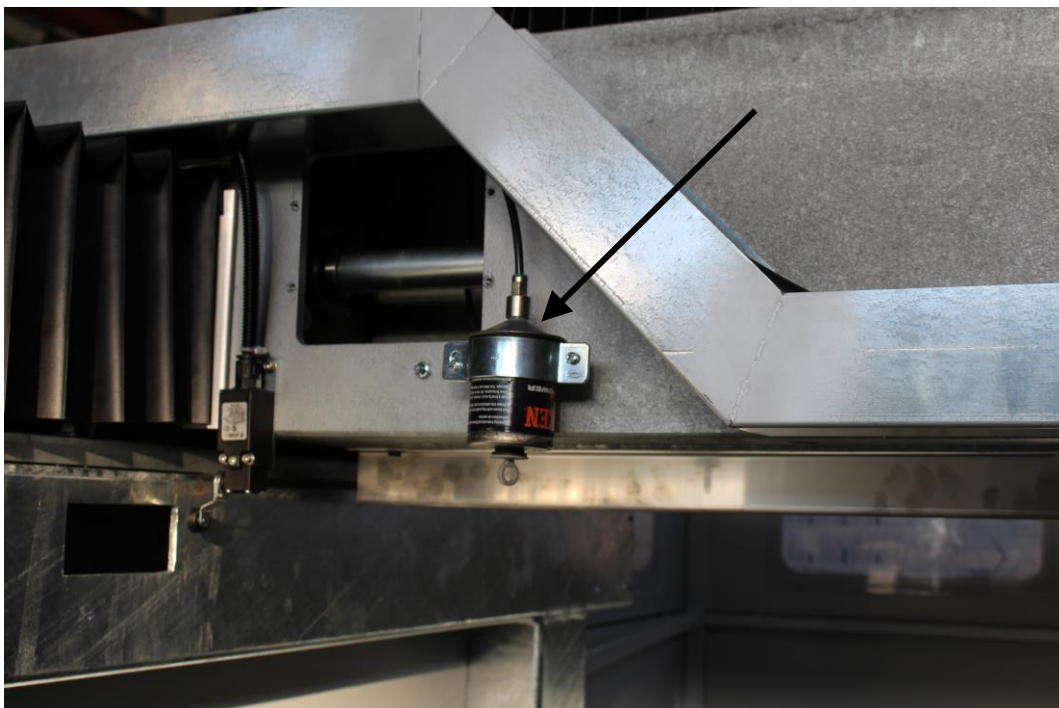



Important: The lifetime of these tanks is 12 months. After this period change them with a new one.

MAINTENANCE

ATTENTION: put the machine in emergency state before making any kind of operation: regulation, reparation, ordinary or extraordinary maintenance and before tools substitution.

- Any damage to the protections, or any anomaly found during the functioning or during the control of the machine must be immediately repaired by a staff trained for that kind of event.
- Before any utilisation verify that the protections and the securities are perfectly efficient and at the end of the work make a general cleaning of the machine.
- Keep good lubricated and clean the exterior side of the dinghy carry disc.
- Periodically control the oil level on the counter uplift local unit.

The building firm will not be responsible for eventual problems, malfunctions, or damages and will no be obliged to furnish guarantee and care in the following cases:

- Protections or safety systems placed on the machine and verified during the test have been removed.
- Modifications or additions done to the machine so causing a variation compared the configuration decided by the building firm. Non siano state rispettate tutte le indicazioni contenute nel presente manuale;
- The machine has not been kept with “the diligence of a good family man”.
- All the needed maintenances and lubrications haven’t been done.

OTHER INFORMATIONS

LIMITS TO THE USE OF THE MACHINE

For this reason the machine must be used according to the dictates of this handbook without making any substantial modifications.

With the term “To modify” we mean any kind of substantial intervention which can cause an alteration the regular functioning of the machines. In this case the label CE emitted by the builder is not more useful, and a new label is needed.

Here there are some fields considered as substantial changes:

Software changes: machine parameters imposed by the builder.

- Electric panels changes which can cause an alterations the electro mechanic and electric function of the machine.
- Use of the cut disc which doesn't follow these characteristics:
 - Diamond disc with diameters between 350-625 mm and maximal thickness of 6 mm.
- Use of the machine outside the project and building limits, that is to say the disassembly of end running, or of pieces and structures for a single use. Wrong use of the turning and folding counter out of the maximal load limit previewed as reported on the label exposed on the machine (modification of the hydraulic control unit).
- Assemble of components not projected by Sassomeccanica (turning counters, structural bridges etc...)

The Sassomeccanica is not responsible for wrong uses of the machine.

PLANS